

Specification of: COPRA PA-C25-EC56-C0000

High-performance centrifugal fan COPRA PLUG with direct drive. With extremely flat, highly efficient motor-impeller unit with permanent magnet motor and integrated controller.

Extremely short compact built-in module with highest system efficiency. Specially designed motor impeller unit. Free from aerodynamic obstructions in the inflow area. Newly developed high performance impeller manufactured automatically from high strength aluminum, step welded, with 5 backward curved blades in profiled 3D design with true airfoil. balanced statically and dynamically according to DIN ISO 21940-11. System inlet cone made of galvanized sheet steel for optimal inflow to the impeller, equipped with flow measuring device IMV as a standard feature. Extremely short internal rotor motor in highly efficient permanent magnet technology with integrated control electronics, in efficiency class IE6, functionally perfectly matched to the impeller. Continuous speed control of the Drive System by 0 ... 10 V analogue signal, or with Modbus RS485-compliant interface. Drive system complete with IP54 protection. Motor and inverter are UL recognized. Due to minimal losses and intelligent cooling concept, no additional motor cooling by air flow required. Magnets without the use of rare earths. Fan can be used in horizontal and vertical axis position. Performance data to DIN 24166 Class 1 (BS 848 Class "A")

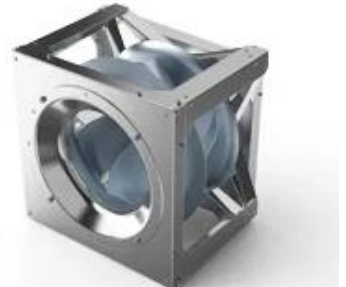
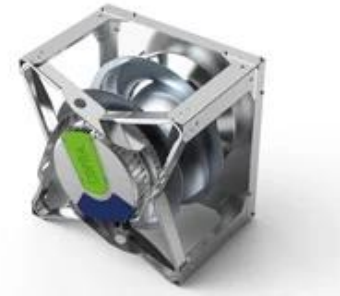

fulfills the ErP requirements 2015

Technical data of the fan: COPRA PA-C25-EC56-C0000

Description	Value Dimension
Installation acc. DIN 24163 Part 1	A
Reference density (Rho1)	1.20 kg/m ³
Medium temperature (t)	20 C
Fan weight	22 kg
Feed data	
Main's frequency (f _N)	50/60 Hz
Voltage (U _N)	3~ 380-480 V
Phases-Voltage-Frequency	3~400-50 V-Hz
Power (P _N)	0 kW
operational limits	
Max. fan speed (n _{vmax})	4200 min ⁻¹
Max. absorbed power of the system (P _{maxS})	1.30 kW
max. current: Inverter out resp. control unit in (I _{max})	2.1 A
Temperature range for conveying medium (t _{min} ... t _{max})	-20...40 C
ErP-Data at best efficiency and density - kg/m³	
measurement- / efficiency category	A / static
design status of VSD	VSD is integrated
overall efficiency (ETA _{opt})	71.0 %
achieved efficiency grade (N _{ist})	80.8
required efficiency grade in 2013 / 2015 (N)	58 / 62
Air flow rate (V _{opt})	2458 m ³ /h
pressure rise (dp _{opt})	1201 Pa
Fan speed (n _{vopt})	4200 min ⁻¹
motor power input (P _{1opt})	1.16 kW
specific ratio (d _{dpopt})	1.012

Fan curve to COPRA PA-C25-EC56-C0000

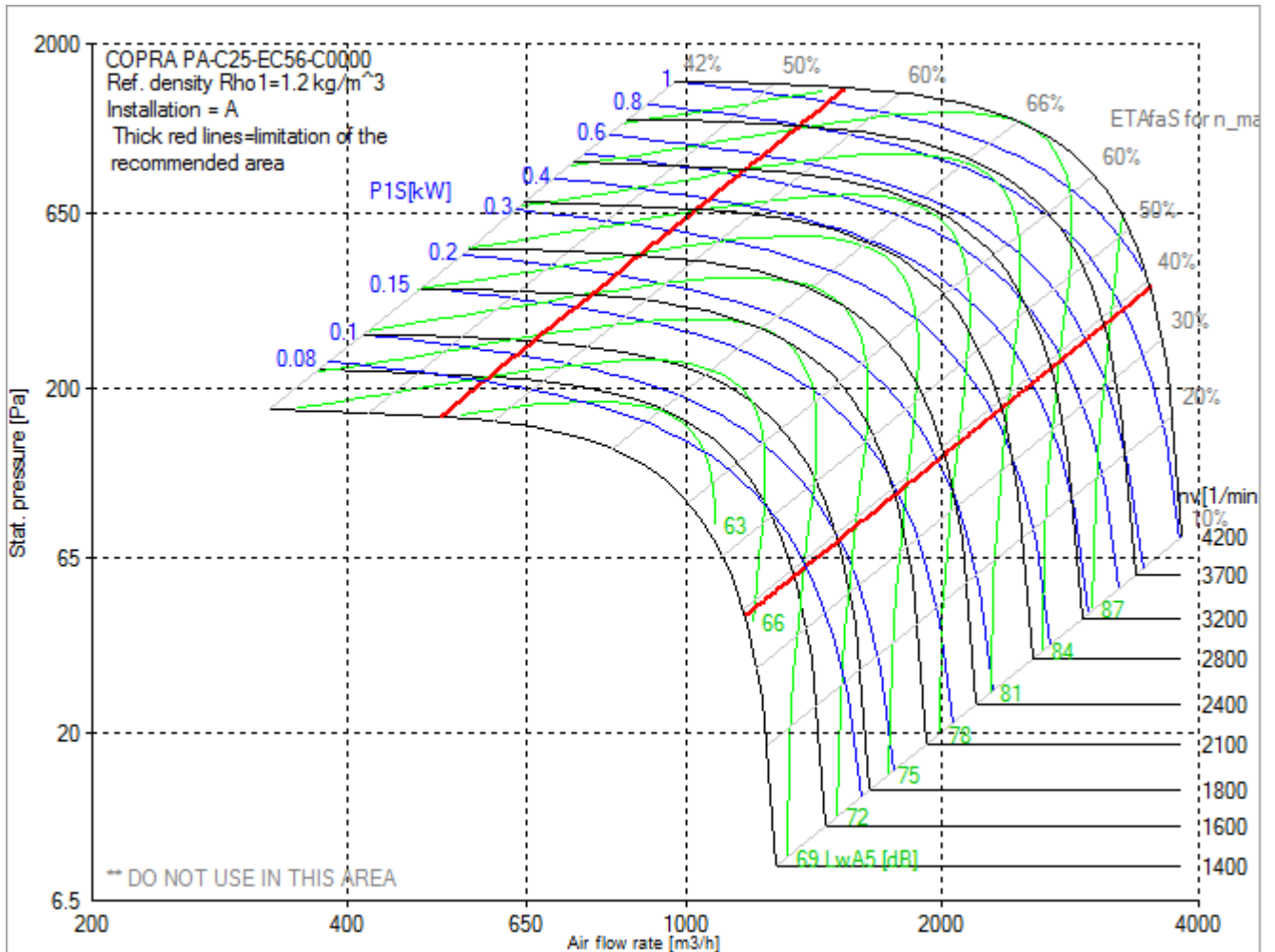

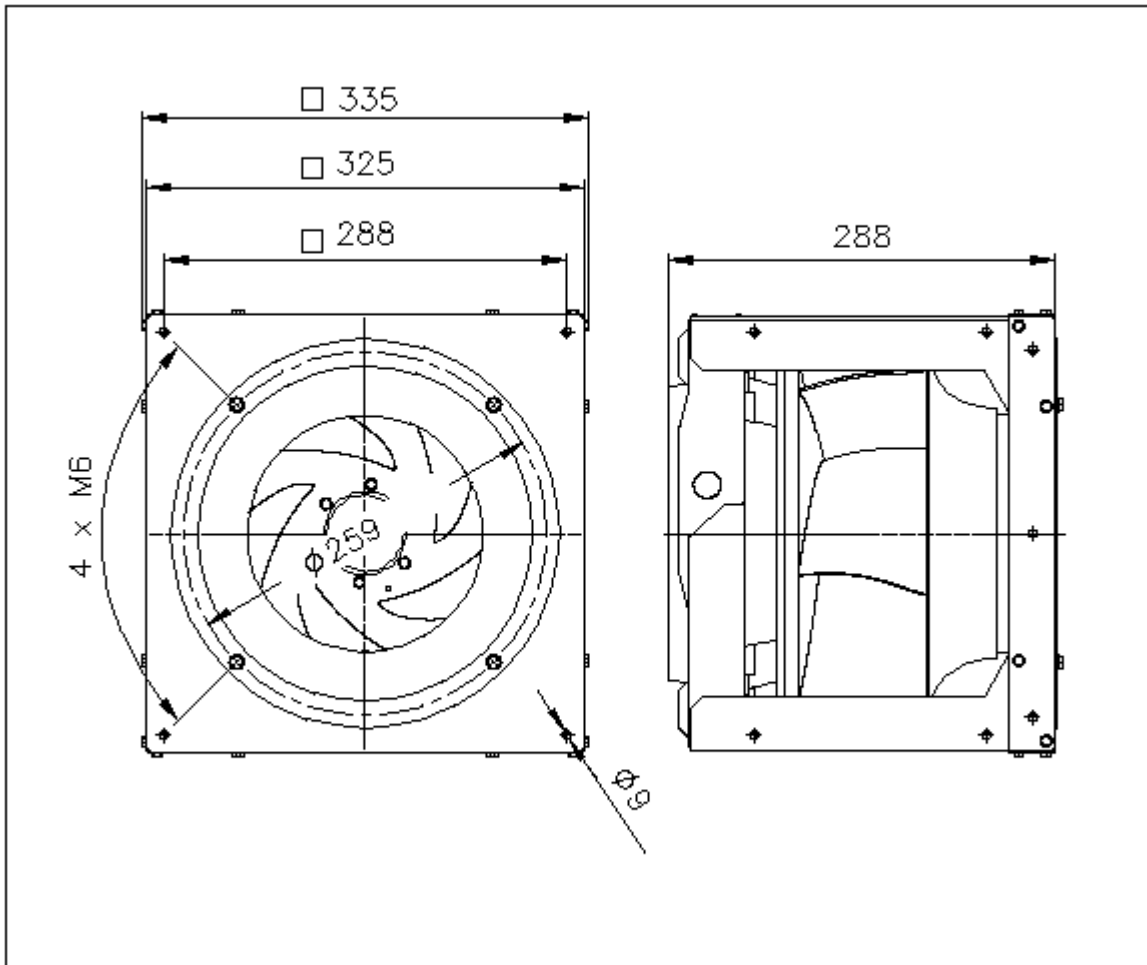

Rotation:
Handing:

LG
90

Wiring diagram of the fan COPRA PA-C25-EC56-C0000

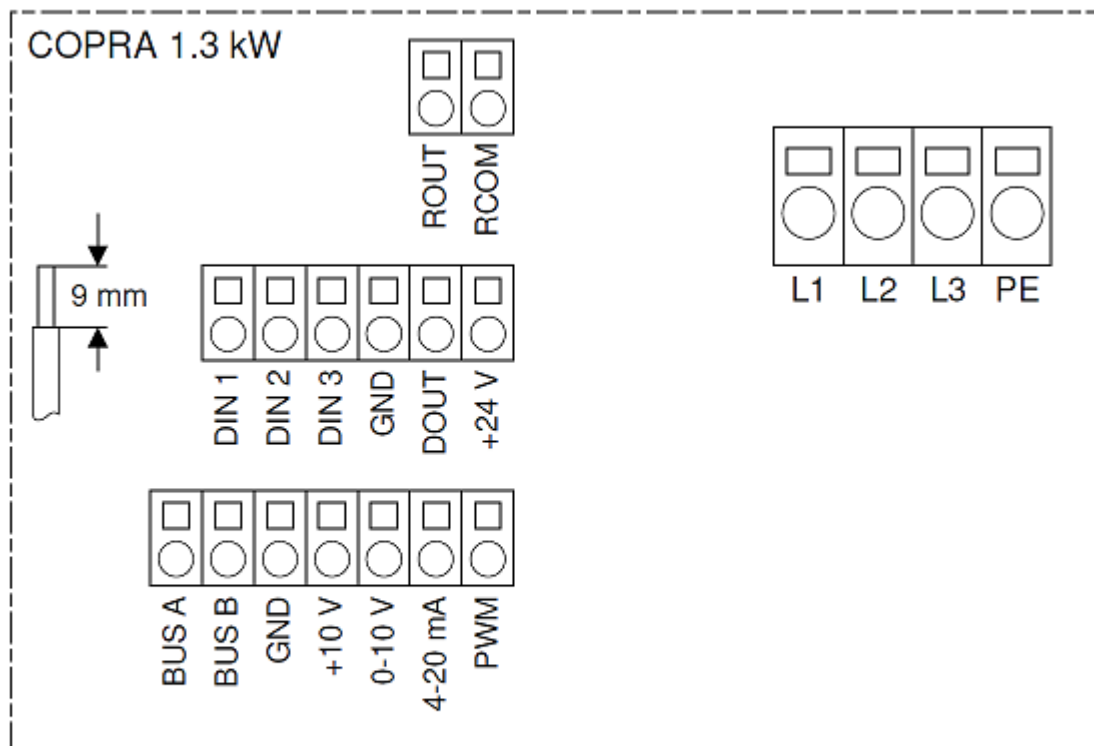

13-07-22 640

Wiring diagram for connection to: [mains - VSD - motor](#)
Rotation: [LG](#)